

Mounting manual EMZY | electronic motorised cylinder

Short version: For the detailed mounting and installation manual see: <http://www.evva.at/products/motorised-cylinder/emzy-electronic-motorised-cylinder/en/>



The EVVA EMZY motorised cylinder offers security, comfort and design. Every EVVA installation may easily and rapidly be upgraded to an electronic locking system with an EMZY motor thumb turn unit.



MZY 35 – motorised cylinder

- Can be integrated in every EVVA locking system.
- Adjustable to every door thickness by modular construction.
- Minimum back set of 35 mm.
- Suitable for all customary escutcheons.
- With spacers a gapless transition between thumb turn and the escutcheon is possible.
- Intuitive thumb turn push button



MCU MI micro control unit

- Mountable in default panel outlets.
- Very fast initialisation by "interactive learn"
- Supply voltage: DC 12V +/- 5% min.1A



Mains adapter for control unit

- Input voltage: AC230V +/-10% 50Hz
- Output voltage: DC 12V / 2A +/- 2%

Outputs of the control units

- ▶ May be reprogrammed and receive another function, see manual
- ▶ Attention: The open collector transistor output is not potential-free
- ▶ The use of an relay control makes a free-wheeling-diode necessary
- ▶ Maximum load of the relay contact = 30 V / 1 A
- ▶ Door openers with a maximum current draw up to 300 mA may be operated with the standard power supply MCU-NT.

Installation of the motorised cylinder

1. Before mounting the motor thumb turn unit has to be inserted in the inner plate of the security escutcheon. The cylinder recess must be enlarged at the bottom by 5mm to avoid mechanical damaging of the cable.
2. Connect the connexion cable EVKA to the motor thumb turn unit. Be careful with the cable routing!
3. Insert the motorised cylinder into the mortise lock.
4. Fix the motorised cylinder and the escutcheon.

Implementation "Interactive Learn"

After the installation of the EMZY the control unit parameters must be set appropriate to the mounting situation. After the power-on the control unit enters a stand-by mode, which only can be left by pushing the learn button on the MCU MI to start the "interactive learn" process.

Proceeding:

- ▶ First turn the EMZY thumb turn manually to the open dead-stop and open the door.
- ▶ For the function "acts like a door push button" release the push button before the door closes.
- ▶ For the function "intelligent push button" press the push button while the door closes.

Two seconds after the closing of the door the motor thumb turn starts turning into the direction dead stop locked and then back into the neutral position. With it the existence of thumb turn push button, the thumb turn push button feature, the direction of rotation, the number of revolutions, the existence of a bolt contact are identified and memorised.

In case of an impossible number of revolutions (e.g. installation error, broken lock) the control unit will identify a failure and change into the state "error". After solving the problem the restart is only possible with power off/on or by pressing the learn button.

Now a 15 sec reset wait time starts. If necessary an emergency lock function and a latch retraction function can be parameterized now. If the reset wait time passes without further action of the user, the EMZY micro control unit restarts without emergency or latch retraction function.

- ▶ With an emergency mortise lock the handle must be pressed within the wait time and an emergency opening must be performed. After the closing of the door the EMZY locks the door, the emergency feature is memorised and the reset wait time starts again.
With a non-emergency mortise lock this point can be skipped.

- ▶ **NOTE:** The EMZY is not compatible with all emergency mortise locks. Clarify it with the lock manufacturer.

- ▶ **Latch retraction:** Push the thumb turn push- or the door push button within the wait time and wait until the open neutral position is reached. The reset wait time starts again. Turn the thumb turn manually in the open direction, open and close the door to save the parameters for the latch retraction function.

- ▶ **Ready for operation:** Wait for the end of the reset time and the restart of the control unit, and then the EMZY-MIKRO will be ready for operation. The "interactive learn" process can be restarted at any time by pressing the learn button.



Mounting manual EMZY | electronic motorised cylinder

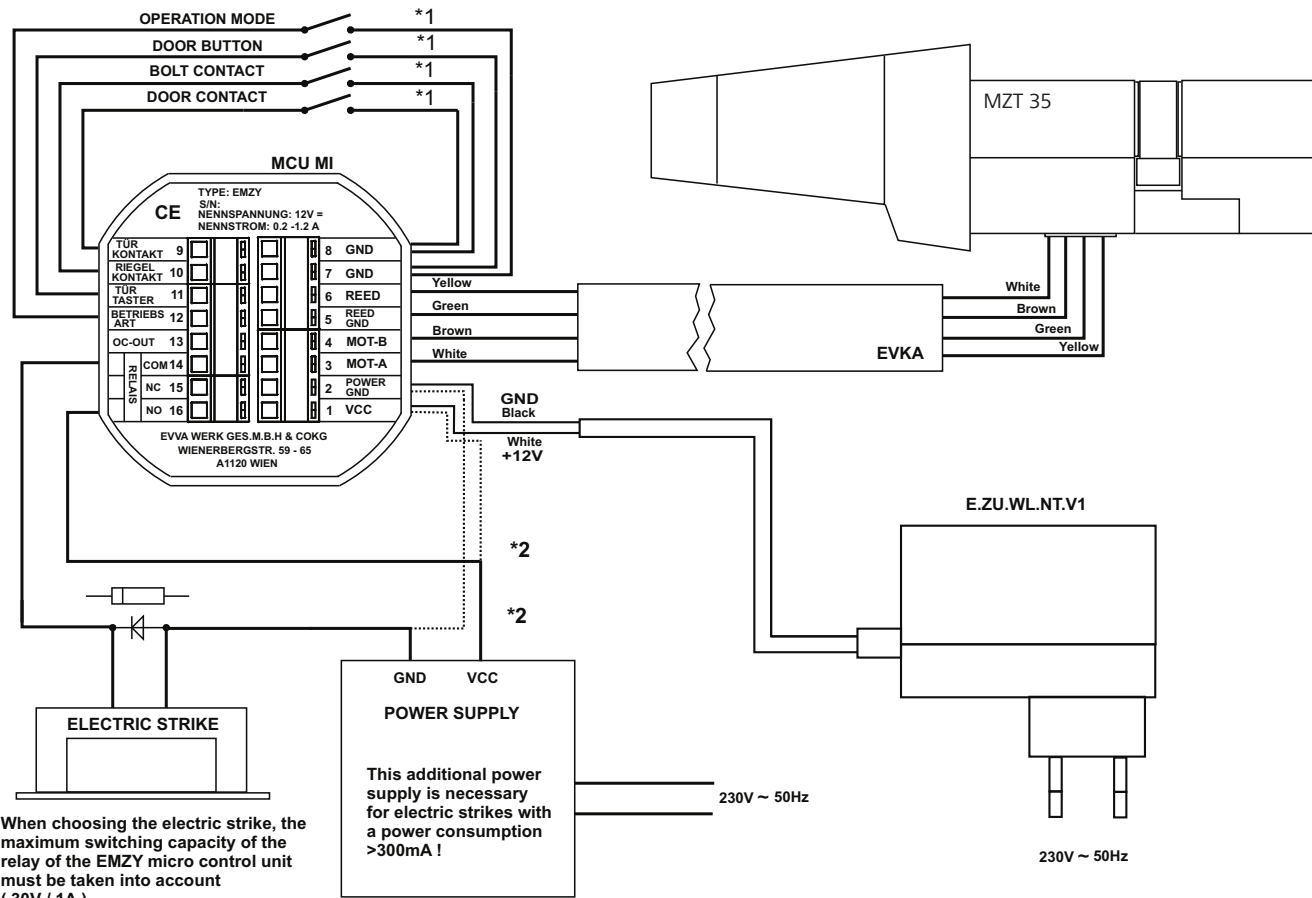

When choosing the electric strike, the maximum switching capacity of the relay of the EMZY micro control unit must be taken into account (30V / 1A).

*1 Max. cable length 10 m

*2 12V default electric strike with a current consumption of max. 300mA and a EMZY Micro control unit can be supplied together by an EMZY micro power supply MCU NT.



The installation of the power supply shall only be carried out by instructed personal.

For a successful learning process the EMZY should be turn a minimum angular degree of 45° over is his Zero-Position (key withdrawal position) in both directions. Attention: There are mortise locks which don't allow that.

Connection of the control unit

Clamp	Allocation	Remarks
1	Supply +	DC 12V
2	Supply -	Ground
3	Mot - A (white)	Motor Knob
4	Mot - B (brown)	Motor Knob
5	Reed - (green)	Sensor Knob
6	Reed + (yellow)	Sensor Knob
9	8 Door contact	closed = Door closed
10	8 Bolt contact	closed = bolted
11	7 Door push button	closed = open
12	7 Operation mode	closed = Day setting
13	Locking state 1) 2)	closed = Door locked
14	16 Door opener 1) 3)	closed = Door opened

Installation of the motorised cylinder EMZY

